

Structural Testing Equipments - Reaction frame

The structural testing consists of a steel reaction frame, loading and data acquisition and processing systems. The reaction frame is similar to the one in *Building Research Institute, Tsukuba, Japan*.

The equipments for structural testing is used:

- To test of the representative vulnerable structural systems and components;
- To test of the efficient and innovative retrofitting techniques;
- To develop constitutive laws for vulnerable structural components.

The following load combinations are possible with the provided equipment:

- 1) Bending with shear for beams testing,
- 2) Bending with shear and axial load for columns, shear walls and portal frames.

The maximum weight of tested specimens is 7t to and the maximum dimensions of the tested specimens are 2.5m by 3 m



Reaction frame

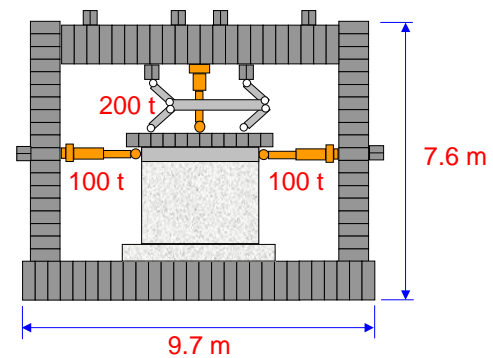

Capacity of reaction frame

One vertical jack with capacity of 200 tons and two horizontal jacks of 100 tons capacity each form the loading system.



Automatic loading system (by RIKEN Japan)

Data acquisition

TDS-302 data logger and one SSW-50C switch box are used to collect the data measured by transducers and strain gages. The SSW-50C switch box was connected to the data logger TDS-300. The data logger is connected to a computer. The TDS-7130 static measurement software is used to read, analyze and store the measured data. The data acquisition system is produced by TML.

The displacement and force transducers are made by TML (Tokyo Sokki Kenkyujo Co. Ltd), Japan. Each transducer has its own Transducer Test Data.

